

## Model

Designation	<b>NLE8.8CN</b>	<b>220-240V/50Hz 1~</b>	Sales code:	<b>105H6880</b>
-------------	-----------------	-------------------------	-------------	-----------------

## Compressor design

Oil type	Polyolester	Refrigerant(s)	<b>R290</b>
Oil viscosity	19,2cSt	Displacement	8,76cm <sup>3</sup> / 0,53cu.in
Oil quantity	270cm <sup>3</sup> / 9,1fl.oz	Compressors on pallet	80
Refr. charge - tech. limit	150g / 5,3oz		
Free gas volume comp.	2360cm <sup>3</sup> / 79,8fl.oz		
Weight	10,9kg / 24lbs		
Motor protection	1# internal		
Winding resistance main	9,28Ω (at 25°C)		
Winding resistance aux	11,64Ω (at 25°C)		
Max. winding temp.	125°C / 257°F		
Max. discharge temp.	120°C / 248°F		



## General - Configurations with NLE8.8CN

	<b>Conf. 1</b>	<b>Conf. 2</b>	<b>Conf. 3</b>
Motorconfiguration	CSIR	RSIR	RSCR
Power supply (nominal)	220-240V/50Hz	220-240V/50Hz	220-240V/50Hz
Number of phases	1	1	1
Voltage range	198-254V	198-254V	198-254V
Approvals	VDE, CCC	VDE, CCC	VDE, CCC
Starting torque	HST	LST	LST
Note	- / -		

## Applications with NLE8.8CN

	<b>Conf. 1</b>	<b>Conf. 2</b>	<b>Conf. 3</b>
Refrigerant	R290	R290	R290
Application	LBP+MBP	LBP+MBP	LBP+MBP
System cooling	fan 3m/s	fan 3m/s	fan 3m/s
Hot gas defrost	OK	OK	OK
Long interval pull down	OK	OK	OK

## Electrical data - Configurations with NLE8.8CN

	<b>Conf. 1</b>	<b>Conf. 2</b>	<b>Conf. 3</b>
Starting device type	relay	PTC	PTC
Run capacitor	-/-	-/-	4μF
Start capacitor	80μF	-/-	-/-
LRA (locked rotor amps / 4s)	11,3A	10,7A	10,1A
RLA (rated load amps / 1s)	2,15A	2,15A	2,05A
Cut in current	11,3A	15,9A	15,9A
IP class	21	21	21

## Model

Designation	<b>NLE8.8CN</b>	220-240V/50Hz 1~	Sales code:	<b>105H6880</b>
-------------	-----------------	------------------	-------------	-----------------

## Compressor dimensions

<b>Housing</b>	A Height	203mm / 7,99in
	B Height	197mm / 7,76in
	C Length shell	205mm / 8,07in
	D Length w. cover	254mm / 10in
	E Width	166mm / 6,54in

Connectors		Suction	Discharge	Process
		X	Y	Z
Diameter	[mm]	øi 8,11-8,29	øi 6,11-6,29	øi 6,11-6,29
(i:inside, o:outside)	[in]	øi 0,32-0,33	øi 0,24-0,25	øi 0,24-0,25
Material		copper	copper	copper
Horizontal angle	±2°	0°	0°	0°
Vertical angle	±2°	15°	21°	155°
Position l/h/w	[mm]	132/69/56	94/99/86	-111/92/72
	[in]	5,2/2,7/2,2	3,7/3,9/3,4	-4,4/3,6/2,8
Straight tube l.	[mm]	12	12	12
	[in]	0,5	0,5	0,5

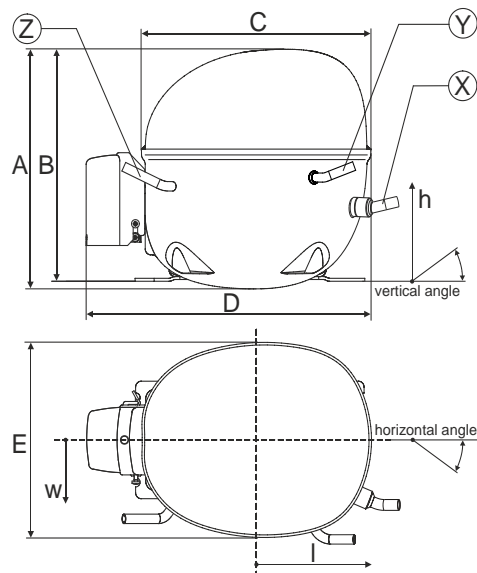

## Compressor fixation

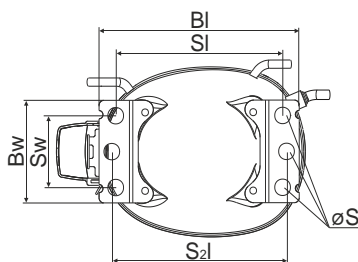

Baseplate	[mm]	[inch]
BI	204	8.03
BW	100	3.94
Small holes		
SI	170	6.7
SW	70	2.76
S1	178	7
øS	ø 16	ø 0.63

### Bolt joint

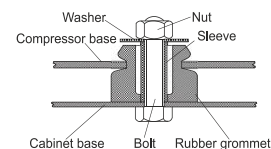

### Snap-on

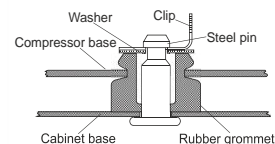

## Mounting accessories

	one comp.	multi pack
Bolt joint   M6   ø16mm	118-1917	118-1918
Bolt joint   ø1/4"   ø16mm	118-1946	
Snap-on   ø7,3   ø16mm	118-1947	118-1919

## Model

Designation	<b>NLE8.8CN</b>	<b>220-240V/50Hz</b>	<b>Conf. 1</b>	Sales code:	<b>105H6880</b>
-------------	-----------------	----------------------	----------------	-------------	-----------------

## Configuration

Motorconfiguration	CSIR
Power supply (nominal)	220-240V/50Hz 1~
Refrigerant	R290
Application	LBP+MBP
Voltage range	198-254V
Starting torque	HST
Approvals	VDE
	CCC

## Electrical accessories / wiring diagram

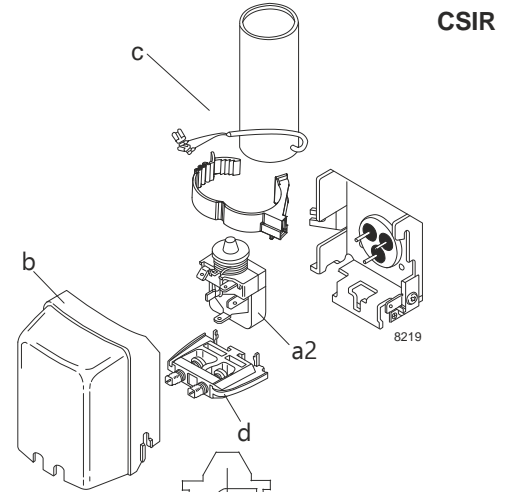

## Ambient temperatures / system cooling

Ambient temperature min.:	10°C / 50°F
Ambient temperature max.:	43°C / 110°F

System cooling (n/a: outside limits)			
T ambient	LBP	MBP	HBP
32°C / 90°F	fan 3m/s	fan 3m/s	n/a
38°C / 100°F	fan 3m/s	fan 3m/s	n/a
43°C / 110°F	fan 3m/s	fan 3m/s	n/a

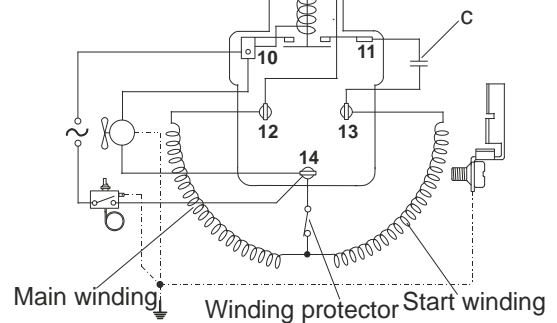

## Operation pressure range

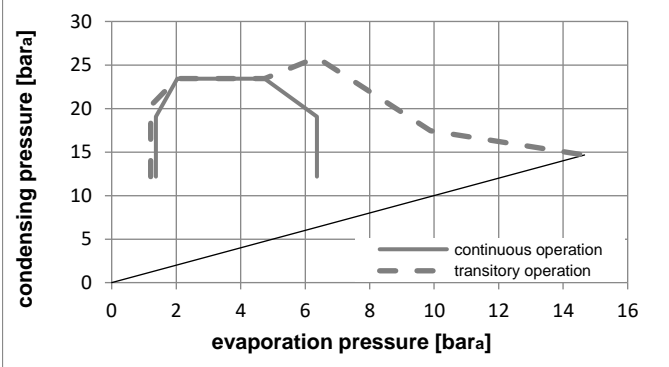
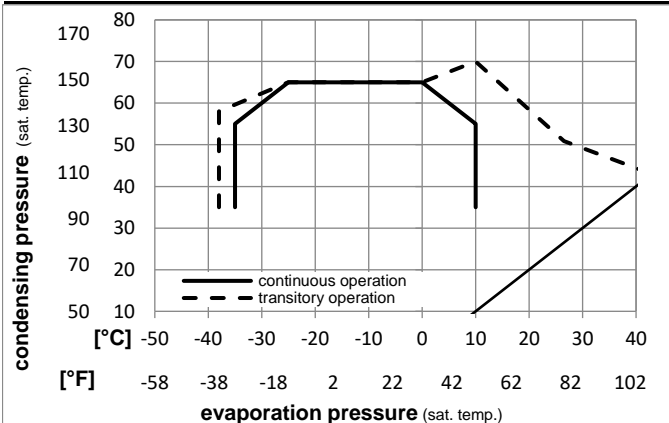

## Components

a2	relay	117U7002
c	start capacitor (80μF)	117U5015
b	plastic cover	103N2010
d	cord relief	103N1010

## Alternative components

b	plastic cover	103N2011
---	---------------	----------

## Model

Designation **NLE8.8CN 220-240V/50Hz** Conf. 1 Sales code: **105H6880**

## Optimization + standard conditions

220-240V/50Hz 1~, CSIR, fan 3m/s, VDE, CCC

	Evaporating pressure (saturation temperature)				Condensing pressure (saturation temperature)						Power consumption			ASHRAE LBP
	pe	pc	RGT	Tliq	Cooling capacity			COP	EER	P1	I	Ref. mass flow		
	[°C]	[°F]	[°C]	[°F]	[W]	[Btu/h]	[kcal/h]	[W/W]	[Btu/Wh]	[kcal/Wh]	[W]	[A]	[kg/h]	
	-23,3	54,4	32,2	32,2	429,7	1468	369,8	1,56	5,34	1,35	274,9	1,76	4,35	ASHRAE LBP
	-10	130	90	90										
	-25	55	32	55	321,7	1099	276,9	1,22	4,16	1,05	264,4	1,73	4,01	cecomaf LBP
	-13	131	89,6	131										
	-35	40	20	40	255,5	873	219,9	1,26	4,30	1,08	203,2	1,55	2,92	EN12900 LBP
	-31	104	68	104										
	-6,66	54,4	35	46,1	752,3	2569	647,4	1,98	6,75	1,70	380,8	2,15	8,58	ASHRAE MBP
	20	130	95	115										
	-10	55	32	55	598,8	2045	515,3	1,65	5,64	1,42	362,3	2,08	7,57	cecomaf MBP
	14	131	89,6	131										
	-10	45	20	45	669,9	2288	576,6	2,05	7,01	1,77	326,5	1,95	8,23	EN12900 MBP
	14	113	68	113										

## Performance tables

220-240V/50Hz 1~, CSIR, fan 3m/s, VDE, CCC

	pe	Cooling capacity			COP	EER	P1	I	m		
	[°C]	[°F]	[W]	[Btu/h]	[kcal/h]	[W/W]	[Btu/Wh]	[kcal/Wh]	[W]	[A]	[kg/h]
[°C / °F]	-35	-31	248,0	847	213,4	1,20	4,10	1,03	206,5	1,56	2,78
cond. pressure	-25	-13	384,8	1314	331,2	1,51	5,16	1,30	254,8	1,70	4,34
pc= 45/113	-15	5	576,2	1968	495,9	1,90	6,48	1,63	303,6	1,86	6,56
return gas temp.	-10	14	697,4	2382	600,2	2,14	7,29	1,84	326,5	1,95	7,98
RGT= 32/90	0	32	1001,2	3419	861,7	2,73	9,34	2,35	366,2	2,10	11,61
liquid temp	5	41	1187,9	4057	1022,3	3,11	10,63	2,68	381,8	2,16	13,90
Tliq= 45/113	10	50	1400,4	4783	1205,2	3,56	12,16	3,06	393,5	2,21	16,55
[°C / °F]	-35	-31	189,1	646	162,8	0,94	3,21	0,81	201,2	1,54	2,34
cond. pressure	-25	-13	321,7	1099	276,9	1,22	4,16	1,05	264,4	1,73	4,01
pc= 55/131	-15	5	493,3	1685	424,5	1,49	5,10	1,29	330,1	1,96	6,20
return gas temp	-10	14	598,8	2045	515,3	1,65	5,64	1,42	362,3	2,08	7,57
RGT= 32/90	0	32	859,5	2935	739,7	2,04	6,95	1,75	422,2	2,32	11,04
liquid temp	5	41	1018,8	3479	876,8	2,27	7,76	1,95	448,6	2,43	13,21
Tliq= 55/131	10	50	1200,1	4099	1032,8	2,54	8,69	2,19	471,7	2,53	15,74

## Model

Designation	<b>NLE8.8CN</b>	<b>220-240V/50Hz</b>	<b>Conf. 2</b>	Sales code:	<b>105H6880</b>
-------------	-----------------	----------------------	----------------	-------------	-----------------

## Configuration

Motorconfiguration	RSIR
Power supply (nominal)	220-240V/50Hz 1~
Refrigerant	R290
Application	LBP+MBP
Voltage range	198-254V
Starting torque	LST
Approvals	VDE
	CCC

## Electrical accessories / wiring diagram

RSIR

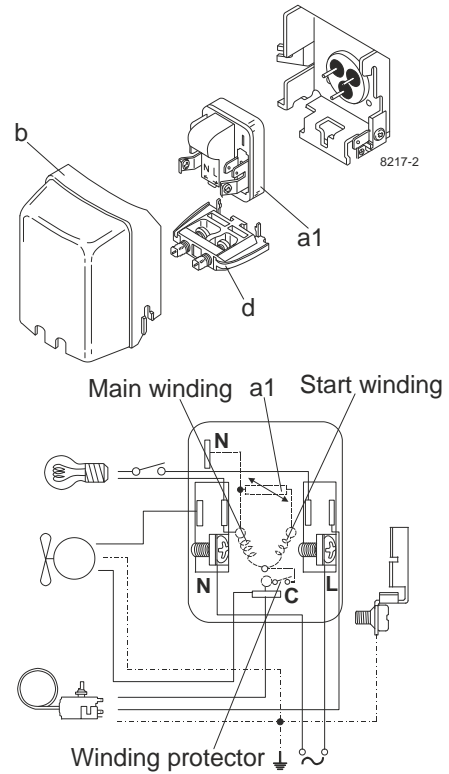

## Ambient temperatures / system cooling

Ambient temperature min.:	10°C / 50°F
Ambient temperature max.:	43°C / 110°F

System cooling (n/a: outside limits)			
T ambient	LBP	MBP	HBP
32°C / 90°F	fan 3m/s	fan 3m/s	n/a
38°C / 100°F	fan 3m/s	fan 3m/s	n/a
43°C / 110°F	fan 3m/s	fan 3m/s	n/a

## Operation pressure range

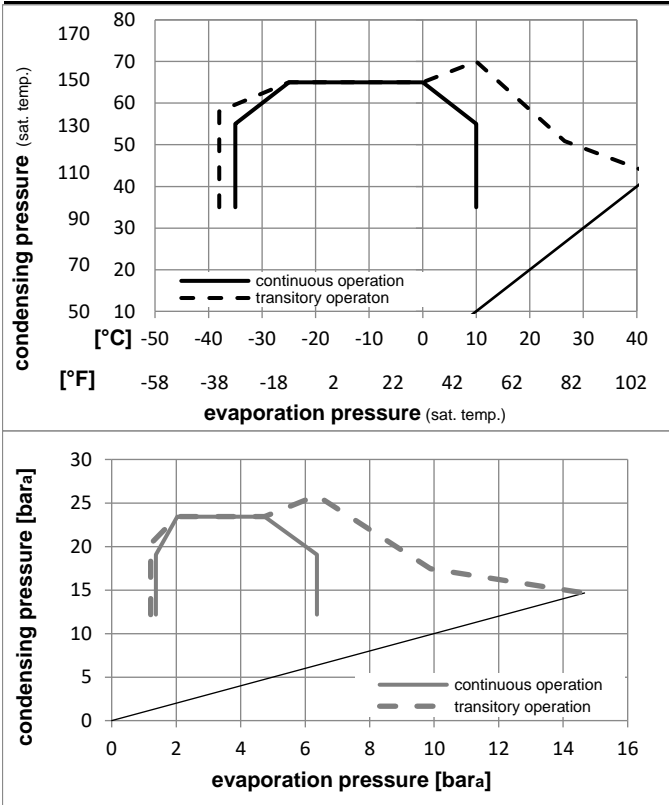

## Components

a1	e-PTC starter (220V, 250hm, 4.8mm)	103N0050
b	plastic cover	103N2010
d	cord relief	103N1010

## Alternative components

b	plastic cover	103N2011
---	---------------	----------

## Model

Designation **NLE8.8CN 220-240V/50Hz** Conf. **2** Sales code: **105H6880**

## Optimization + standard conditions

220-240V/50Hz 1~, RSIR, fan 3m/s, VDE, CCC

Evaporating pressure (saturation temperature)														
Condensing pressure (saturation temperature)														
Return gas temp.														
Liquid temp.														
Cooling capacity														
COP														
EER														
Power consumption														
Current consumption														
Ref. mass flow														
	pe	pc	RGT	Tliq	[W]	[Btu/h]	[kcal/h]	[W/W]	[Btu/Wh]	[kcal/Wh]	P1 [W]	I [A]	m [kg/h]	
[°C]	-23,3	54,4	32,2	32,2	429,7	1468	369,8	1,56	5,34	1,35	274,9	1,76	4,35	ASHRAE LBP
[°F]	-10	130	90	90										
[°C]	-25	55	32	55	321,7	1099	276,9	1,22	4,16	1,05	264,4	1,73	4,01	cecomaf LBP
[°F]	-13	131	89,6	131										
[°C]	-35	40	20	40	255,5	873	219,9	1,26	4,30	1,08	203,2	1,55	2,92	EN12900 LBP
[°F]	-31	104	68	104										
[°C]	-6,66	54,4	35	46,1	752,3	2569	647,4	1,98	6,75	1,70	380,8	2,15	8,58	ASHRAE MBP
[°F]	20	130	95	115										
[°C]	-10	55	32	55	598,8	2045	515,3	1,65	5,64	1,42	362,3	2,08	7,57	cecomaf MBP
[°F]	14	131	89,6	131										
[°C]	-10	45	20	45	669,9	2288	576,6	2,05	7,01	1,77	326,5	1,95	8,23	EN12900 MBP
[°F]	14	113	68	113										

## Performance tables

220-240V/50Hz 1~, RSIR, fan 3m/s, VDE, CCC

	pe	Cooling capacity			COP			EER			P1	I	m
	[°C]	[°F]	[W]	[Btu/h]	[kcal/h]	[W/W]	[Btu/Wh]	[kcal/Wh]	[W]	[A]	[kg/h]		
[°C / °F]	-35	-31	248,0	847	213,4	1,20	4,10	1,03	206,5	1,56	2,78		
cond. pressure	-25	-13	384,8	1314	331,2	1,51	5,16	1,30	254,8	1,70	4,34		
pc= 45/113	-15	5	576,2	1968	495,9	1,90	6,48	1,63	303,6	1,86	6,56		
return gas temp.	-10	14	697,4	2382	600,2	2,14	7,29	1,84	326,5	1,95	7,98		
RGT= 32/90	0	32	1001,2	3419	861,7	2,73	9,34	2,35	366,2	2,10	11,61		
liquid temp	5	41	1187,9	4057	1022,3	3,11	10,63	2,68	381,8	2,16	13,90		
Tliq= 45/113	10	50	1400,4	4783	1205,2	3,56	12,16	3,06	393,5	2,21	16,55		
[°C / °F]	-35	-31	189,1	646	162,8	0,94	3,21	0,81	201,2	1,54	2,34		
cond. pressure	-25	-13	321,7	1099	276,9	1,22	4,16	1,05	264,4	1,73	4,01		
pc= 55/131	-15	5	493,3	1685	424,5	1,49	5,10	1,29	330,1	1,96	6,20		
return gas temp	-10	14	598,8	2045	515,3	1,65	5,64	1,42	362,3	2,08	7,57		
RGT= 32/90	0	32	859,5	2935	739,7	2,04	6,95	1,75	422,2	2,32	11,04		
liquid temp	5	41	1018,8	3479	876,8	2,27	7,76	1,95	448,6	2,43	13,21		
Tliq= 55/131	10	50	1200,1	4099	1032,8	2,54	8,69	2,19	471,7	2,53	15,74		

### Model

Designation	<b>NLE8.8CN</b>	<b>220-240V/50Hz</b>	<b>Conf. 3</b>	Sales code:	<b>105H6880</b>
-------------	-----------------	----------------------	----------------	-------------	-----------------

### Configuration

Motorconfiguration	RSCR
Power supply (nominal)	220-240V/50Hz 1~
Refrigerant	R290
Application	LBP+MBP
Voltage range	198-254V
Starting torque	LST
Approvals	VDE
	CCC

### Electrical accessories / wiring diagram

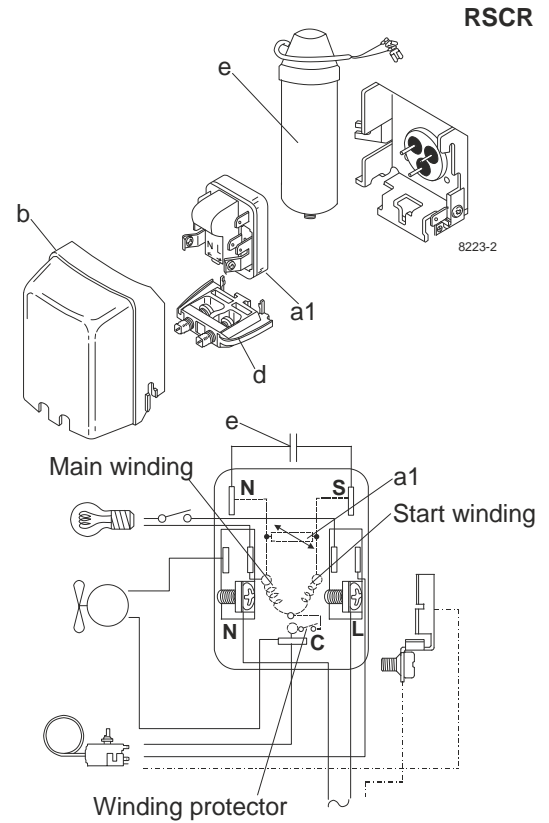

### Ambient temperatures / system cooling

Ambient temperature min.:	10°C / 50°F
Ambient temperature max.:	43°C / 110°F

System cooling (n/a: outside limits)			
T ambient	LBP	MBP	HBP
32°C / 90°F	fan 3m/s	fan 3m/s	n/a
38°C / 100°F	fan 3m/s	fan 3m/s	n/a
43°C / 110°F	fan 3m/s	fan 3m/s	n/a

### Operation pressure range

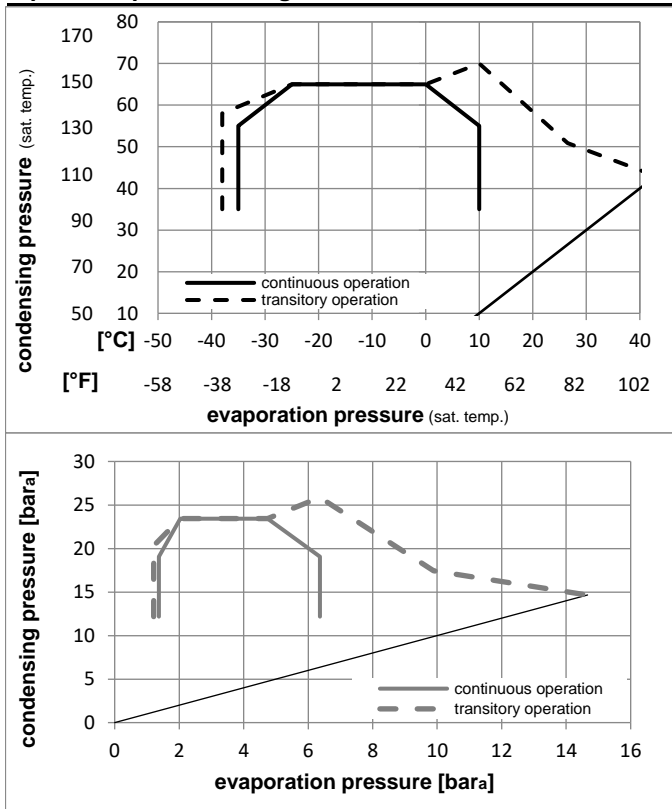

### Components

a1	e-PTC starter (220V, 250hm, 4.8mm)	103N0050
e	run capacitor (4μF, 4.8mm)	117-7119
b	plastic cover	103N2010
d	cord relief	103N1010
	bracket for run capacitor	117-0300
	screw M4x8mm	117-0301

### Alternative components

b	plastic cover	103N2011
---	---------------	----------

## Model

Designation **NLE8.8CN 220-240V/50Hz** Conf. **3** Sales code: **105H6880**

## Optimization + standard conditions

220-240V/50Hz 1~, RSCR, fan 3m/s, VDE, CCC

	Evaporating pressure (saturation temperature)				Condensing pressure (saturation temperature)						Power consumption			ASHRAE LBP
	pe	pc	RGT	Tliq	Cooling capacity			COP	EER		P1	I	Ref. mass flow	
	[°C]	[°F]	[°C]	[°F]	[W]	[Btu/h]	[kcal/h]	[W/W]	[Btu/Wh]	[kcal/Wh]	[W]	[A]	[kg/h]	
	-23,3	54,4	32,2	32,2	434,0	1482	373,5	1,64	5,62	1,42	263,8	1,46	4,40	ASHRAE LBP
	-10	130	90	90										
	-25	55	32	55	324,9	1110	279,6	1,28	4,37	1,10	253,8	1,43	4,05	cecomaf LBP
	-13	131	89,6	131										
	-35	40	20	40	258,1	881	222,1	1,32	4,49	1,13	196,2	1,30	2,95	EN12900 LBP
	-31	104	68	104										
	-6,66	54,4	35	46,1	759,8	2595	653,9	2,08	7,10	1,79	365,6	1,89	8,67	ASHRAE MBP
	20	130	95	115										
	-10	55	32	55	604,8	2065	520,5	1,74	5,94	1,50	347,8	1,80	7,65	cecomaf MBP
	14	131	89,6	131										
	-10	45	20	45	676,6	2311	582,3	2,15	7,33	1,85	315,1	1,70	8,31	EN12900 MBP
	14	113	68	113										

## Performance tables

220-240V/50Hz 1~, RSCR, fan 3m/s, VDE, CCC

	pe	Cooling capacity			COP	EER		P1	I	m	
	[°C]	[°F]	[W]	[Btu/h]	[kcal/h]	[W/W]	[Btu/Wh]	[kcal/Wh]	[W]	[A]	[kg/h]
[°C / °F]	-35	-31	250,5	855	215,6	1,26	4,30	1,08	198,8	1,31	2,81
cond. pressure	-25	-13	388,7	1327	334,5	1,58	5,41	1,36	245,3	1,42	4,38
pc= 45/113	-15	5	582,0	1988	500,8	1,99	6,79	1,71	292,7	1,60	6,62
return gas temp.	-10	14	704,4	2406	606,2	2,24	7,64	1,92	315,1	1,70	8,06
RGT= 32/90	0	32	1011,2	3454	870,3	2,86	9,76	2,46	353,7	1,89	11,73
liquid temp	5	41	1199,8	4097	1032,5	3,26	11,12	2,80	368,6	1,97	14,04
Tliq= 45/113	10	50	1414,4	4831	1217,3	3,73	12,72	3,21	379,7	2,02	16,71
[°C / °F]	-35	-31	191,0	652	164,4	0,99	3,37	0,85	193,5	1,26	2,36
cond. pressure	-25	-13	324,9	1110	279,6	1,28	4,37	1,10	253,8	1,43	4,05
pc= 55/131	-15	5	498,2	1701	428,8	1,57	5,37	1,35	316,9	1,67	6,26
return gas temp	-10	14	604,8	2065	520,5	1,74	5,94	1,50	347,8	1,80	7,65
RGT= 32/90	0	32	868,1	2965	747,1	2,14	7,32	1,85	404,9	2,07	11,15
liquid temp	5	41	1029,0	3514	885,6	2,39	8,18	2,06	429,7	2,18	13,34
Tliq= 55/131	10	50	1212,1	4140	1043,2	2,69	9,18	2,31	451,1	2,28	15,89