



APPROVALS



ENGINEERING CODE
212BA04

APPROVED REFRIGERANT
R-134a

POWER SUPPLY
220-240 V 50 Hz

STANDARD CONDITIONS
ASHRAE

APPLICATION
HBP

COOLING CAPACITY
1954 W (HBP)

EFFICIENCY
2.71 W/W (HBP)

MOTOR TYPE
CSCR

STARTING TORQUE
HST

DATA

General Data

Type	Hermetic reciprocating
Technology Type	On-Off
Displacement	20.44 cm ³
Compressor Cooling	Fan/NotControlled/220
Fan Air Flow	520 m ³ /h
Expansion Device	Capillary Tube or Expansion Valve
Horse Power	3/4 hp
Max Condensing Pressure Operating	13.92 bar
Max Condensing Pressure Peak	15.62 bar
Power Supply	220-240 V 50 Hz
Evaporating Temperature Range	-15 °C to 10 °C

Electrical Data

Motor type	CSCR
Starting Torque	HST
Start Winding Resistance	11.22 Ω at 25° C
Run Winding Resistance	3 Ω at 25° C

Mechanical Data

Maximum Recommended Refrigerant Charge	800 g
Oil Charge	450 ml
Oil Type Configuration	ESTER
Oil Type Viscosity	ISO22
Pressurization	Dry air charge
Weight	17 Kg
Free Internal Volume	3.3 L

Electrical Components

	Description
Run Capacitor	15
Start Capacitor	72-88 Uf / 330 V
CSR / CSIR Box	YES
Motor Protection	T0634/G9
Starting Device	RVA2M3C-111

External Characteristics

Base Plate	Universal	
Tray Holder	No	
Height	220 mm	
Connector	Internal Diameter	Shape
Suction	9.6 mm	Vertical/Copper
Discharge	6.42 mm	Vertical/Copper
Process	6.42 mm	Vertical/Copper

PERFORMANCE

Rated Points

Condensing Temperature	Evaporating Temperature	Cooling Capacity	Power Consumption	Current	Gas Flow Rate	Efficiency
54.40°C	7.20°C	1954 W	721 W	3.38 A	43.28 kg/h	2.71 W/W

Test Condition: ASHRAEHBP46, Fan/NotControlled/220, Return Gas 35°C, Evaporation 7.20°C, Condensing 54.40°C, Ambient 35°C, Liquid 46.1°C, Subcooling 8.3K. Data in accordance to EN

12900:2013 and AHRI 540:2015 polynomial equation and uncertainty guidance.

Performance Curve Data

Condensing Temperature 35°C

Evaporating Temperature °C	Cooling Capacity W	Power W	Current A	Gas Flow Rate kg/h	Efficiency W/W
-15	952	431	2.15	17.56	2.21
-10	1203	464	2.28	22.28	2.59
-5	1508	498	2.43	28.04	3.03
0	1874	533	2.58	34.98	3.52
5	2304	569	2.74	43.24	4.05
10	2804	606	2.91	52.97	4.63

Test Condition: ASHRAEHBP46, Fan/NotControlled/220, Return Gas 35°C, Ambient 35°C, Subcooling 8.3K. Data in accordance to EN 12900:2013 and AHRI 540:2015 polynomial equation and uncertainty guidance.

Condensing Temperature 45°C

Evaporating Temperature °C	Cooling Capacity W	Power W	Current A	Gas Flow Rate kg/h	Efficiency W/W
-15	839	457	2.26	16.73	1.84
-10	1060	501	2.44	21.21	2.12
-5	1331	545	2.62	26.73	2.44
0	1656	591	2.8	33.44	2.81
5	2042	637	2.99	41.46	3.21
10	2491	684	3.19	50.94	3.64

Test Condition: ASHRAEHBP46, Fan/NotControlled/220, Return Gas 35°C, Ambient 35°C, Subcooling 8.3K. Data in accordance to EN 12900:2013 and AHRI 540:2015 polynomial equation and uncertainty guidance.

Condensing Temperature 55°C

Evaporating Temperature °C	Cooling Capacity W	Power W	Current A	Gas Flow Rate kg/h	Efficiency W/W
-10	916	541	2.6	19.97	1.69
-5	1150	593	2.83	25.20	1.94
0	1434	646	3.06	31.60	2.22
5	1772	700	3.3	39.32	2.53
10	2170	755	3.54	48.49	2.88

Test Condition: ASHRAEHBP46, Fan/NotControlled/220, Return Gas 35°C, Ambient 35°C, Subcooling 8.3K. Data in accordance to EN 12900:2013 and AHRI 540:2015 polynomial equation and uncertainty guidance.

Operating Envelope

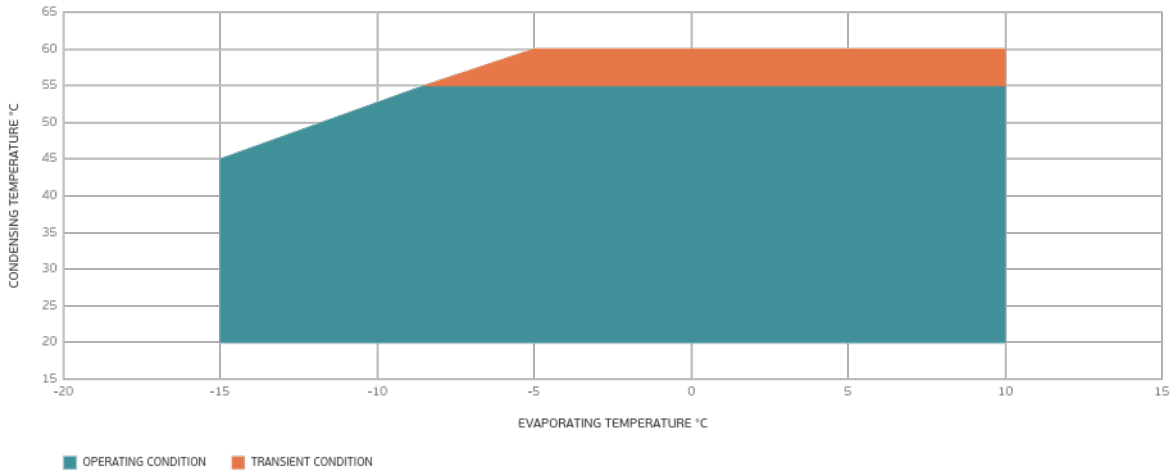

External Dimensions

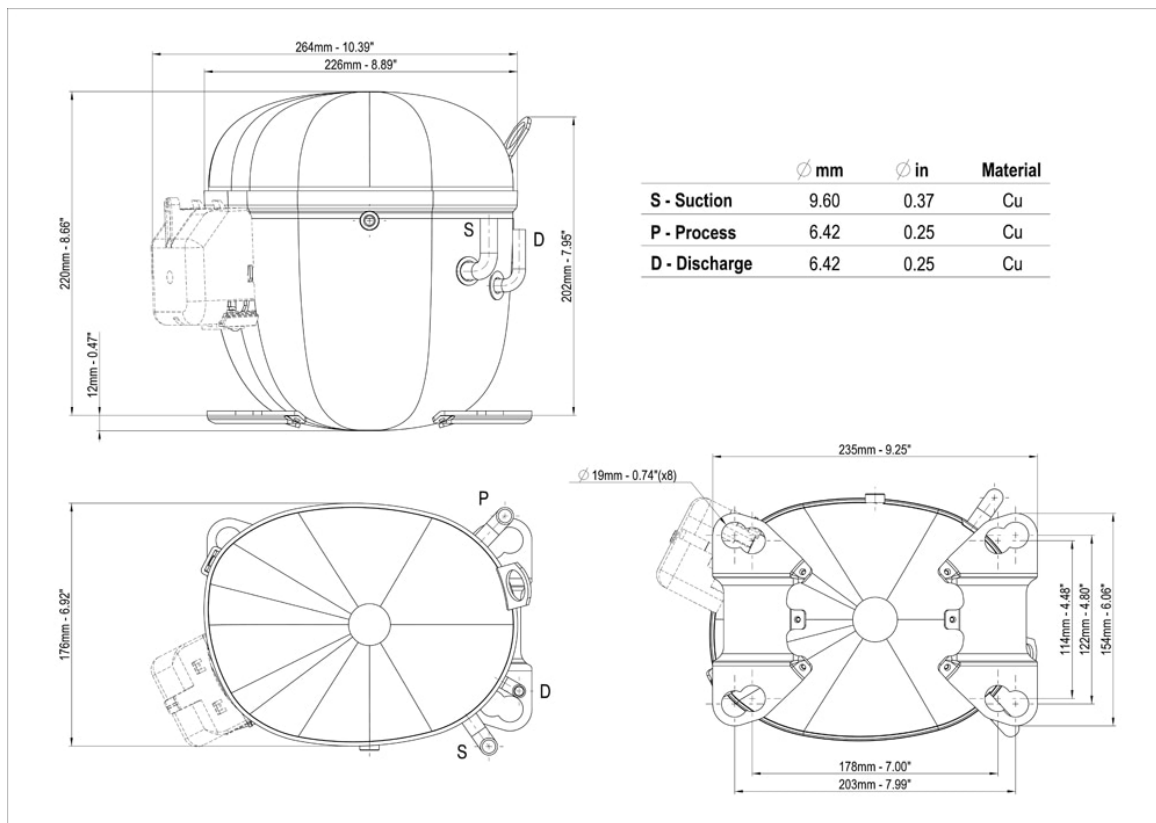

Wiring Diagram

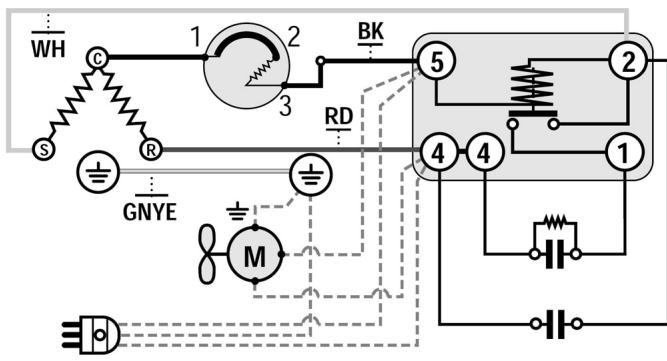

Assembly Instructions

